

For CataLyst-5, A465 and F3 Robots

Robot Tracks

Extend Your Robot Work Envelope



- Increases Work Envelope
- Integrated With Robot Motion
- 1-5 Meter Lengths

CRS Robotics offers a unique option to extend the work envelope of our Robots and Plate Movers with our Linear Robot Tracks. Linear Tracks come in standard one-meter lengths, up to five meters total length (longer reaches available upon request).

In addition to providing a significantly increased work area for the robot, the Linear Robot Tracks enable the CataLyst-5, A465, and F3 robots to attend to multiple processes concurrently.

The movement of the Linear Robot Track is powered by a closed-loop servomotor drive and, like the robot itself, is controlled by the C500C controller.

The Track simply becomes an added degree of freedom for the robot: using our RAPL-3 programming language or ActiveRobot™ ActiveX® components, you program location, speed, and acceleration as easily as any other movement of the robot. It's completely integrated and fully supported by our cutting edge POLARA™ laboratory automation software.

The motion of the robot along the track can be programmed for speeds from 0.01 m/s to 0.8 m/s (F3T), 0.9 m/s (T475), or 1.0 m/s (CataLyst-T). Position repeatability is better than 0.08 mm. Acceleration is 3 m/s².

The CataLyst-T, T475 and F3T Linear Robot Tracks may be mounted in an upright or optional inverted position.

- Lab Automation • Education • Material Application
- Material Handling • Assembly • Product Testing



Linear Tracks

CataLyst-5 + Linear Track = CataLyst-T

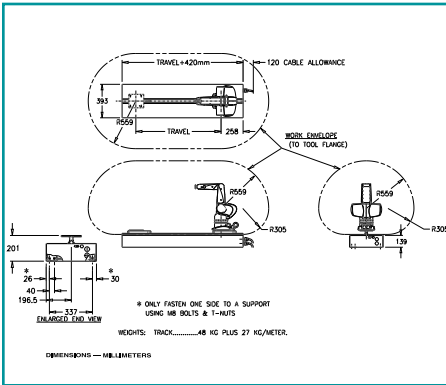

CataLyst-T Plan and Elevation Views

Model CataLyst-T Performance Features

- Six degrees of freedom
- Nominal payload: 1 kg
- Track velocity: 0.01 to 1.0 m/s
- Acceleration: 3.0 m/s²
- Repeatability: 0.08 mm [0.003 in.]
- Standard track travel: 1, 2, 3, 4, and 5 meters
- Mounting: upright or optional inverted position



A465 Robot + Linear Track = T475 Robot

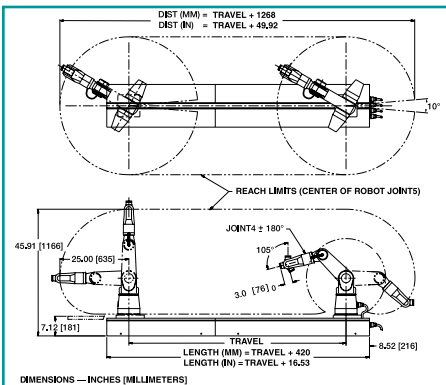

Model T475 Plan and Elevation Views

Model T475 Performance Features

- Seven degrees of freedom
- Nominal payload: 2 kg
- Track velocity: 0.01 to 0.9 m/s
- Acceleration: 3.0 m/s²
- Repeatability: 0.08 mm [0.003 in.]
- Standard track travel: 1, 2, 3, 4, and 5 meters
- Mounting: upright or optional inverted position



F3 Robot + Linear Track = F3T Robot

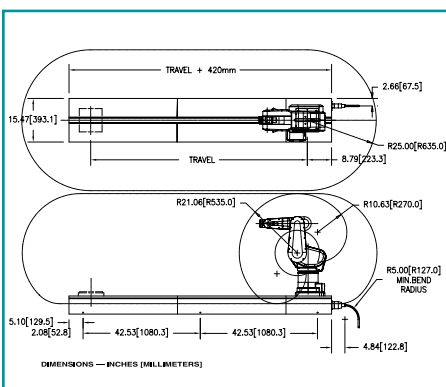

Model F3T Plan and Elevation Views

Model F3T Performance Features

- Seven degrees of freedom
- Nominal payload: 3 kg
- Track velocity: 0.01 to 0.8 m/s
- Acceleration: 3.0 m/s²
- Repeatability: 0.08 mm [0.003 in.]
- Standard track travel: 1, 2, 3, 4, and 5 meters
- Mounting: upright or optional inverted position



Contact

CRS Robotics Corporation
5344 John Lucas Drive
Burlington, Ontario
L7L 6A6 Canada
Phone: (905) 332-2000
Fax: (905) 332-1114

USA and Canada Toll Free:
1-800-365-7587
www.crsrobotics.com
Email: info@crsrobotics.com

Safety Compliance Standards	
CE (European)	EN55011:1991
EM Emissions:	EN50082-1:1992
EM Immunity:	EN775:1992
Machine Safety:	ISO 10218:1992 (E)
	EN60204-1:1992
	EN292:191
	15.06-1992
ANSI/RIA	
CSA (Canadian) Process Control Equipment	C22.2 No. Z434-94
CSA Std:	CAN/CSA-C22.5 No 68-92
Motor Operated:	
Appliances	

