

F3 Microplate Mover

F3 Microplate Mover™



If you need to automate the loading, unloading, and storage of microtiter plates, look no further. CRS offers a series of plate movers that provide smooth, fast, and reliable motion to ensure that your assays are processed promptly and reliably. F3 is a robust mover with an articulated wrist joint that adds the ability to re-orient plates. The F3 also offers a linear track option for tending multiple instruments.

All CRS plate movers are programmed with ActiveRobot™, the ActiveX™ programming component for automating lab instruments. ActiveRobot (www.activerobot.com) provides complete control of the mover from such COM-compliant programming languages as Microsoft Visual Basic®, Visual C++®, and Borland Delphi™. It is an ideal solution for users who need to add plate automation to an instrument with its own Windows® development software. If your instrument lacks a Windows user interface or if it must support such advanced features as plate tracking, plate scheduling, and unattended runs, CRS offers POLARA™ Workstation, the open architecture laboratory automation software that brings unprecedented control, productivity, and versatility to your process.

F3 is well suited for transferring plates between such single-plate and multi-plate lab instruments as:

- Readers
- Liquid Handlers
- Shakers
- Incubators
- Delidder Stations
- Washers



Microplate Carousel



Standalone Hotel



Lab Tables



Delidder Station



F3 Microplate Mover

Dimensions

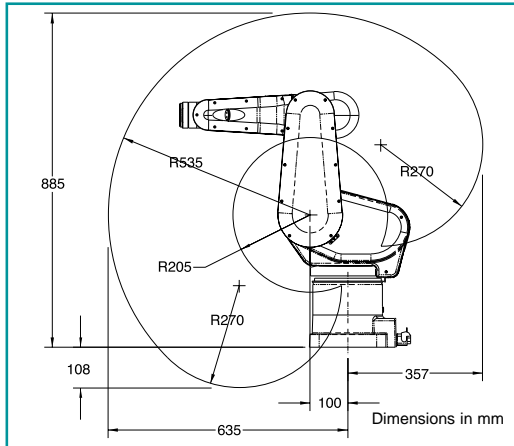

Elevation View (w/o gripper)

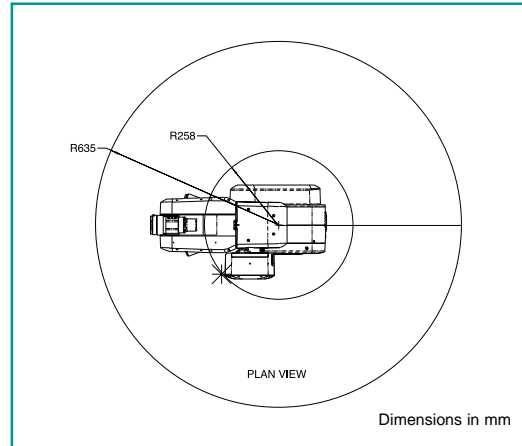

Plan View (w/o gripper)

Safety Compliance Standards	
CE (European)	
EM Emissions:	EN55011:1991
EM Immunity	EN50082-1:1992
Machine Safety:	EN775:1992
	ISO 10218:1992 (E)
	EN60204-1:1992
	EN292:191
ANSI/RIA	15.06-1992
CSA (Canadian) Process Control Equipment	
CSA Std:	C22.2 No. Z434-94
Motor Operated :	CAN/CSA-C22.s No 68-92
Appliances	

Features

- Fast and versatile: runs 24/7
- True random access capabilities: load/unload plates from front, top, or side of instrument
- Absolute encoders: no homing, start moving plates on power up
- Easy to integrate: automate plate handling with ActiveRobot™ or advanced processes with POLARA™ Workstation software
- Articulated wrist: maintain full control over plate orientation

Performance Specifications

Payload	3 kg (nominal)	6.6 lb
Reach (no gripper)	710 mm	28 in.
Reach (std. gripper)	863 mm	34.0 in.
Repeatability	± 0.05 mm	± 0.002 in.
Weight	53 kg	115 lb

Options

- Servo gripper with microplate fingers: holds plates in portrait and landscape orientation; senses plate presence
- ActiveRobot or POLARA Workstation software
- 15-plate, standalone, random access Microplate Hotels
- 40-plate, standalone, stack access Platefeeder Hotels
- Microplate Carousel: 200-plate (random access); 320-plate (stack access)
- Plate Delidder Station
- Barcode reader
- Linear Track

Axis Work Range Maximum Speed

J1 (waist)	±180°	240°/second
J2 (shoulder)	- 135° / + 45°	210°/second
J3 (elbow)	± 135°	240°/second
J4 (wrist rotate)	± 180°	375°/second
J5 (wrist pitch)	± 135°	300°/second
J6 (wrist roll)	unlimited	375°/second

Contact

CRS Robotics Corporation
5344 John Lucas Drive
Burlington, Ontario
L7L 6A6 Canada
Phone: (905) 332-2000
Fax: (905) 332-1114

USA and Canada Toll Free:
1-800-365-7587
www.crsrobotics.com
Email: info@crsrobotics.com